

RATINGS



DOE

Boiler model number	0–2,000 feet altitude		2,000–4,500 feet altitude (Canada) ①		Net I=B=R ratings	Boiler water content Gallons	DOE seasonal efficiency % A.F.U.E ②	Vent size	Circulator flange size (Recommended supply & return pipe size, NPT)
	Input	Output (DOE Heating Capacity)	Input	Output					
GWS-063 ③	63,000	54,000	56,700	48,600	47,000	1.5	85.3	3"	1"
GWS-095	95,000	81,000	85,500	72,900	70,000	2.1	84.6	3"	1"
GWS-127	127,000	107,000	114,300	96,300	93,000	2.7	84.0	3"	1"
GWS-158	158,000	133,000	142,200	119,700	115,000	3.3	83.4	3"	1¼"

① Contact your dealer regarding information and parts for high altitude applications.
 ② Based on standard test procedures prescribed by the United States Department of Energy.
 ③ As an Energy Star Partner, Williamson has determined that the GWS-063 meets the Energy Star guidelines for energy efficiency.
 ④ Net I=B=R ratings are based on net installed radiation of sufficient quantity for the requirements of the building and nothing need be added for normal piping and pickup. Ratings are based on a piping and pickup allowance of 1.15. Additional allowance should be made for unusual piping and pickup loads.

DIMENSIONS

ALL DIMENSIONS IN INCHES

GWS boilers are CSA design certified for installation on combustible flooring. (Do not install on carpeting.)

VENTING: Use only AL29-4C venting per instructions in Boiler Manual.

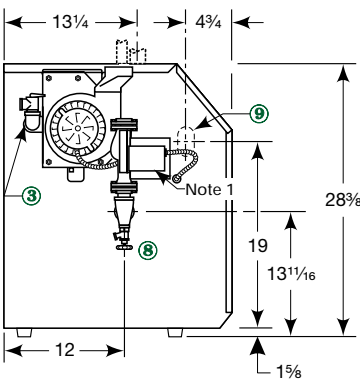

LEFT SIDE

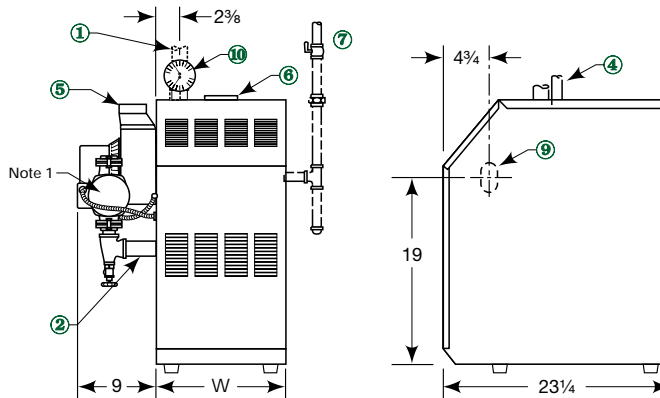

FRONT

RIGHT SIDE

Boiler model	W
	Width
GWS-095	13
GWS-127	16
GWS-158	19
GWS-190	22

- ① Supply piping (Note 1)
- ② Return piping (Note 1)
- ③ Relief valve, 3/4" NPT
- ④ 1/2" NPT to expansion tank/air vent
- ⑤ Vent connection, 3" diameter

- ⑥ 3/3 1/2" diameter air pipe connection
- ⑦ Gas supply piping
- ⑧ Drain valve
- ⑨ Gas supply entrance (right or left side)
- ⑩ Pressure/temperature gauge (in tee on supply)

Note 1: Boiler supply and return tappings are 1 1/2" NPT. Circulator flanges shipped with boiler are sized to recommended pipe size listed in RATINGS table, above.

Boiler circulator is shipped loose. Circulator may be mounted on either boiler supply or return piping.

ORDER CODE

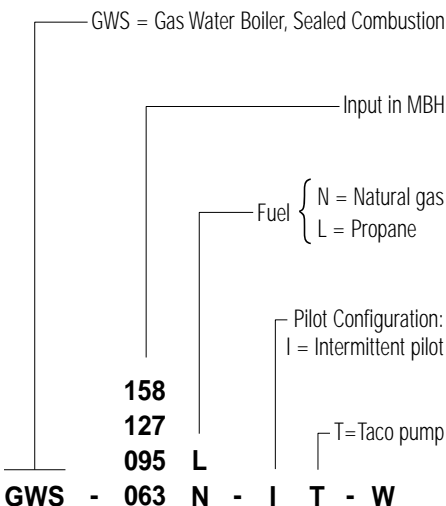

EQUIPMENT

- Factory tested
- Insulated extended steel jacket
- Cast iron sections with built-in air separator
- Induced-draft blower assembly
- Air pressure switch
- Stainless steel burners
- Electrical junction box
- 24-VAC combination gas valve

- 40VA control transformer
- Plug-in wiring
- Taco 007 circulator
- High temperature limit control
- 30 PSIG ASME relief valve
- Combination pressure/temperature gauge
- Spark-ignited (intermittent) pilot system
- Electronic ignition/flame supervisory control

WARRANTY

- Limited lifetime warranty on heat exchanger
- 1-year limited warranty on parts
- Optional 5- or 10-year parts and labor warranty



1819 W. Elizabeth Ave. • Linden, NJ 07036
 www.unionsteam.com (908) 862-4455

Fax (908) 862-3106

Form US-001 (0505)