

UNION STEAM

GW I

Gas-fired Water Boilers

- ❑ Versatile
 - Induced-draft design allows sidewall or chimney venting
- ❑ Compact design
- ❑ Factory tested
- ❑ Easy service
 - One-piece access door
 - All controls in easy reach
 - Color-coded wiring
- ❑ High efficiency
 - AFUE's to 83.3%
 - Spark-ignited pilot with electronic control
- ❑ Cast iron sections with built-in air separator
- ❑ Insulated heavy-gauge steel jacket

- ❑ Induced-draft combustion system
- ❑ Factory-packaged
- ❑ 47,500 to 190,000 Btuh Input
Natural or propane gas



U.S. UNION STEAM

RATINGS



Boiler model number	0–2,000 feet altitude		2,000–4,500 feet altitude (Canada) ①		Net I=B=R ratings	Boiler water content Gallons	DOE seasonal efficiency % A.F.U.E ②	Vent size: Direct exhaust venting	Chimney/breeching size: Atmospheric venting	Circulator flange size (Recommended supply & return pipe size, NPT)
	Input	Output (DOE Heating Capacity)	Input	Output						
	Btuh	Btuh ②	Btuh	Btuh						
GWI-047	47,500	40,000	42,300	36,000	35,000	1.5	83.0	3"	4"	¾"
GWI-063	63,000	53,000	56,700	47,700	46,000	1.5	83.3	3"	4"	1"
GWI-095	95,000	79,000	85,500	71,100	69,000	2.1	83.0	3"	5"	1"
GWI-127	127,000	106,000	114,300	95,400	92,000	2.7	82.7	3"	5"	1"
GWI-158	158,000	131,000	142,200	118,000	114,000	3.3	82.4	3"	5"	1¼"
GWI-190	190,000	157,000	171,000	141,000	137,000	3.8	82.1	3"	5"	1¼"

① Contact your dealer regarding information and parts for high altitude applications.

② Based on standard test procedures prescribed by the United States Department of Energy.

③ Net I=B=R ratings are based on net installed radiation of sufficient quantity for the requirements of the building and nothing need be added for normal piping and pickup. Ratings are based on a piping and pickup allowance of 1.15. Additional allowance should be made for unusual piping and pickup loads.

DOE

DIMENSIONS

ALL DIMENSIONS IN INCHES

GWI boilers are CSA design certified for installation on combustible flooring. (Do not install on carpeting.)

VENTING: When connecting boiler as direct exhaust, use only AL29-4C venting per instructions in Boiler Manual.

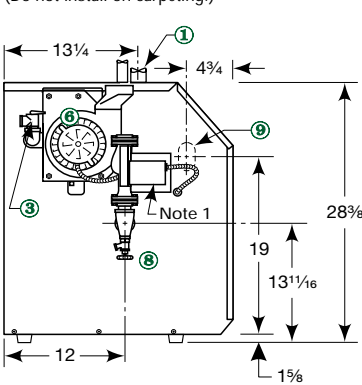

LEFT SIDE

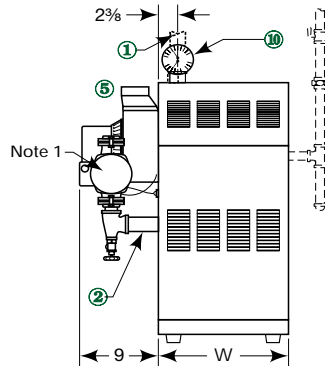

FRONT

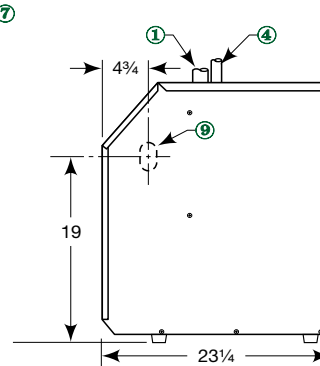

RIGHT SIDE

Boiler model	W
	Width
GWI-047	10
GWI-063	10
GWI-095	13
GWI-127	16
GWI-158	19
GWI-190	22

- ① Supply piping (Note 1)
- ② Return piping (Note 1)
- ③ Relief valve, ¾" NPT
- ④ ½" NPT to expansion tank/air vent
- ⑤ Vent connection, 3" diameter

- ⑥ Inducer
- ⑦ Gas supply piping
- ⑧ Drain valve
- ⑨ Gas supply entrance (right or left side)
- ⑩ Pressure/temperature gauge (in tee on supply)

Note 1: Boiler supply and return tappings are 1½" NPT. Circulator flanges shipped with boiler are sized to recommended pipe size listed in RATINGS table, above.

Boiler circulator is shipped loose. Circulator may be mounted on either boiler supply or return piping.

ORDER CODE

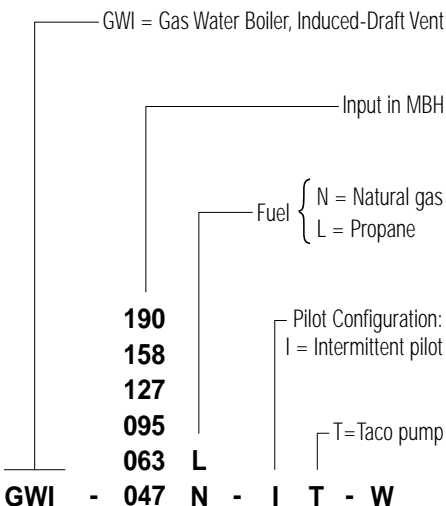

EQUIPMENT

- Factory tested
- Insulated extended steel jacket
- Cast iron sections with built-in air separator
- Induced-draft blower assembly
- Air pressure switch
- Stainless steel burners
- Electrical junction box
- 24-VAC combination gas valve

- Combination relay receptacle and 40VA transformer and plug-in circulator relay
- Taco 007 circulator
- High temperature limit control
- 30 PSIG ASME relief valve
- Combination pressure/temperature gauge
- Spark-ignited (intermittent) pilot system
- Electronic ignition/flame supervisory control

WARRANTY

- Limited lifetime warranty on heat exchanger
- 1-year limited warranty on parts
- Optional 5- or 10-year parts and labor warranty



1819 W. Elizabeth Ave. ■ Linden, NJ 07036

www.unionsteam.com

(908) 862-4455

Fax (908) 862-3106

Form US-001 (0505)